

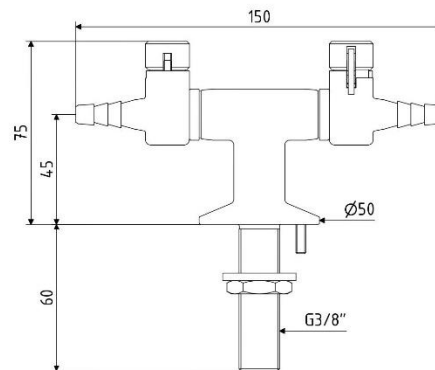

ARBOLES UK LTD

LABORATORY TAPS, SAFETY SHOWERS AND EYE WASHES

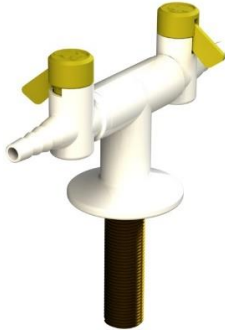

Part No: 900032NG-WA

Description: Two-way 180 degree high visibility droplever gas tap fixed serrated nozzle.

Integral anti-rotation pin.

Applications: Standard laboratory gas tap for Bunsen burner type applications. Suitable for both natural and LPG gas applications.

Construction: All brass body, Rilsan plastic coated, white (RAL 9016).

Identification coding to DIN13792

Connection and mounting: 3/8" BSP male flat ended shank x 60mm long with back nut.

Standard anti-rotation base with location pin. Two mounting holes 17mm and 5mm diameter are required through the work surface, template enclosed.

Service: Natural or LPG gases

Pressure and Flow: Maximum work pressure 20 – 25 Mbar

Flow Rate @ 20Mbar = 1 Cubic metre/hour per nozzle.

Please note: The appliance should be used to size pipe work and not the gas valve (See separate Arboles UK drop lever gas consumption sheet)

British Gas/BSI certified

These items should only be installed by a person competent to do so.

ARBOLES UK LTD

Unit 56 • Flexspace Business Centre • Manchester Road • Bolton • BL3 2NZ T: 0044 (0)1204 388814 F: 0044 (0)1204 388813

sales@arboles.co.uk www.arboles.co.uk

