



ARBOLES UK LTD

LABORATORY TAPS, SAFETY SHOWERS AND EYE WASHES



Part No: 900295DW-W

Description: Special water Pillar tap with removable serrated nozzle.

Applications: Specifically designed for use on special recirculating water to avoid risk of contamination from base materials. Suitable for pure water applications.

Construction: All brass body, Rilsan plastic coated, white (RAL9016).

All internal components manufactured from polypropylene.

Quarter turn handwheel operation.

Chemical resistant plastic ABS handwheel, Identification coding to DIN13792

Connection and mounting: 3/4" BSP male flat ended shank x 100mm long with back nut for mounting on the work surface. Flexible tube connection 12mm od, inlet and outlet connectors 20mm push in type.

Pressure and Flow: Maximum pressure 50PSI (Recommended 20PSI)

Flow Rate @ 20 psi = 12 Litre/min.

Spares: Handwheel Assembly, Pt No 960180

ARBOLES UK LTD

Unit 56 • Flexspace Business Centre • Manchester Road • Bolton • BL3 2NZ T: 0044 (0)1204 388814 F: 0044 (0)1204 388813

sales@arboles.co.uk www.arboles.co.uk





ARBOLES UK LTD

LABORATORY TAPS, SAFETY SHOWERS AND EYE WASHES

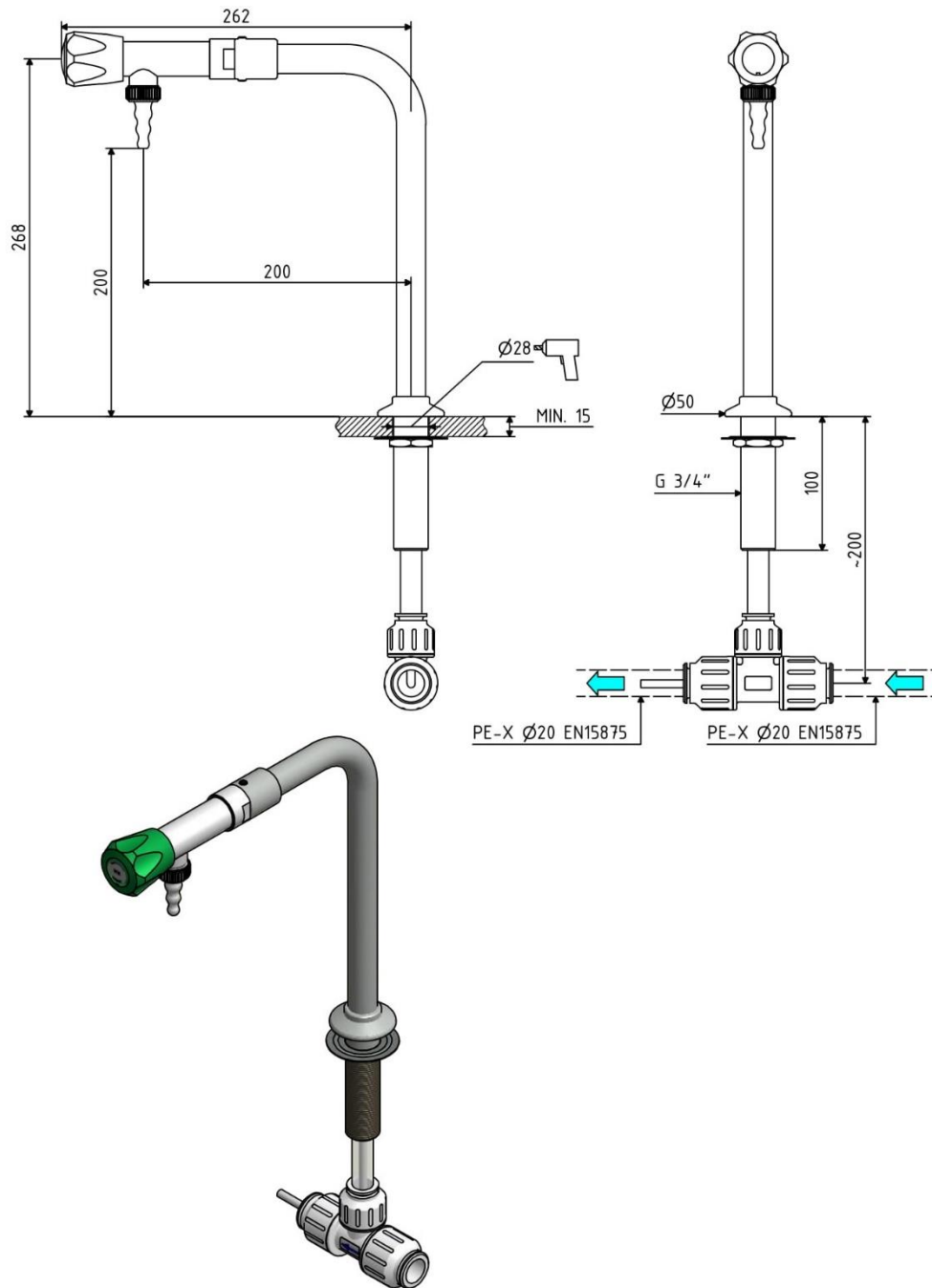

ARBOLES UK LTD

Unit 56 • Flexspace Business Centre • Manchester Road • Bolton • BL3 2NZ T: 0044 (0)1204 388814 F: 0044 (0)1204 388813

sales@arboles.co.uk www.arboles.co.uk

