

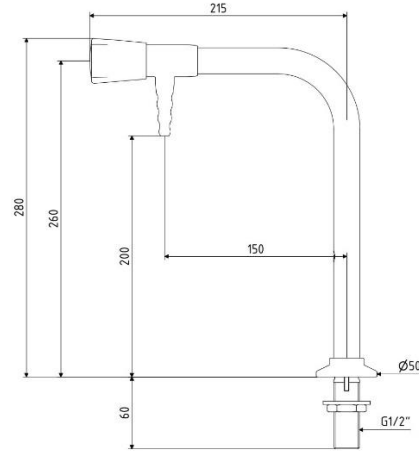

ARBOLES UK LTD

LABORATORY TAPS, SAFETY SHOWERS AND EYE WASHES



Part No: 900120CW-WA

Description: Pillar tap with fixed serrated nozzle.

Applications: Standard laboratory water tap for all applications where header tank supply is present (Full WRAS approval)

Options: Removable or full-bore nozzles are available on request. Hot water

Construction: All brass body, Rilsan plastic coated, white (RAL9016).

Chemical resistant plastic ABS handwheel, Identification coding to DIN13792

Connection and mounting: ½" BSP male flat ended shank x 60mm long with back nut.

Standard anti-rotation base with location pin. Two mounting holes 22mm and 5mm diameter required template enclosed.

Pressure and Flow: Maximum pressure 100PSI (Recommended 20PSI)

Flow Rate @ 20 psi = 12 Litre/min.

Spares: Handwheel Assembly, Pt No 960180

Valve headwork, Pt No 950148

WRAS: Approved

ARBOLES UK LTD

Unit 56 • Flexspace Business Centre • Manchester Road • Bolton • BL3 2NZ T: 0044 (0)1204 388814 F: 0044 (0)1204 388813

sales@arboles.co.uk www.arboles.co.uk

