

SUPPLY

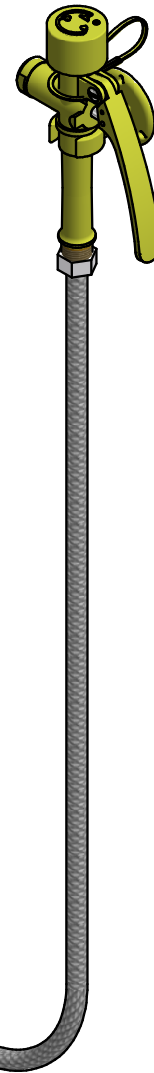

ARBOLES UK LTD

Unit 56 · Flexspace Business Centre · Manchester Road · Bolton · BL3 2NZ
 T: +44 (0)1204 388814 F: +44 (0)1204 388813

sales@arboles.co.uk www.arboles.co.uk

DATE
 October 2020

DIMENSIONS IN MILLIMETERS
 MAY VARY BY ±10mm

Product Dimensions

SIZE
 DIN A4



SCALE
 1 : 5

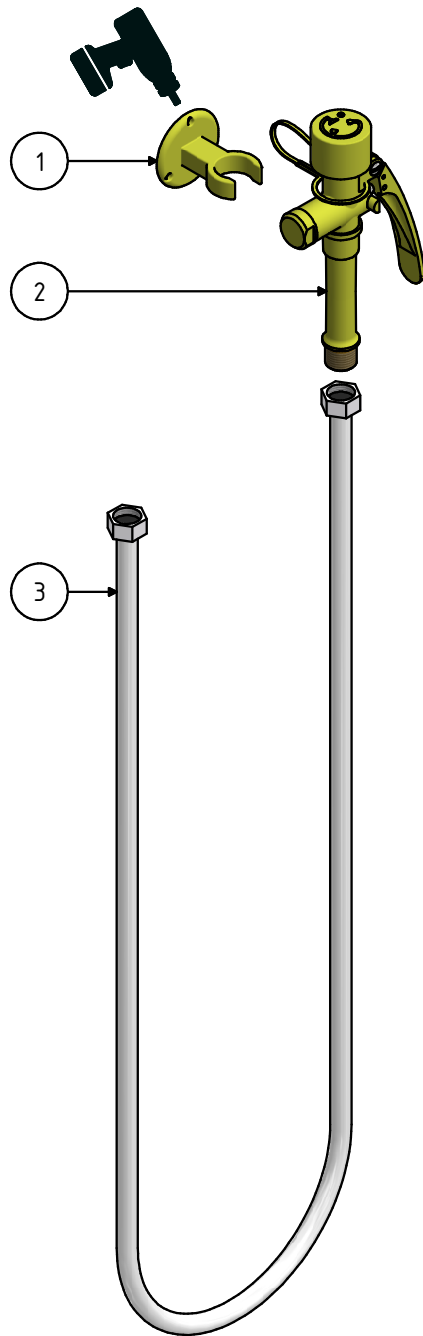

REF.
 3000

Wall Mounted Single Head Eyewash



 Sealant
 Tools to fasten

Item	Qty	Ref.	Descr.
1	1	190109	WALL BRACKET
2	1	190153	SINGLE HEAD EYEWASH
3	1	190149	FLEXIBLE HOSE

ARBOLES UK LTD

Unit 56 · Flexspace Business Centre · Manchester Road · Bolton · BL3 2NZ
 T: +44 (0)1204 388814 F: +44 (0)1204 388813

sales@arboles.co.uk www.arboles.co.uk

DATE
October 2020

Installation Diagram

SIZE
DIN A4

SCALE
1:5

REF.
3000

Wall Mounted Single Head Eyewash